



FABRICANTES DE
MOLINOS DE CAFÉ

MANUFACTURERS
OF COFFEE GRINDERS

Molino de café profesional
para todo tipo de cafés

Professional coffee grinder
for all types of coffee.

SPACE TRON INOX

COLLECTION CLASSIC

TECHNICAL CHARACTERISTICS 0-500gr/5' Max 2Kg

Voltage: 230V / 220V / 110V

Frequency: 50Hz / 60Hz

Phases: 1(monophase)

RPM: 1.300 / 1.600

Current: 1,75A / 3,7A

Capacitor: 10nf / 40nf

Power: 0,20Hp / 356W

Protection rating: IP21

Motor supplied with thermal protector

Maximum operating time: 30 min.

Tempered steel grinding wheel (62HRc) ø 60mm

Lifespan of grinding wheels: 500kg

Hopper capacity: 2kg

Multi-language touch screen

Selection for 1 or 2 freshly ground coffees or continuous grinding

Total or partial coffee counter

Assistant timer grinding point

Dimensions width x length x height: 180x310x615mm

Weight: 9kg

Air noise: 77dB

Diseñado bajo directiva 89/392 CE.



Grinding blades in tempered steel
(62HRc) ø 60mm.

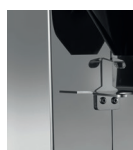
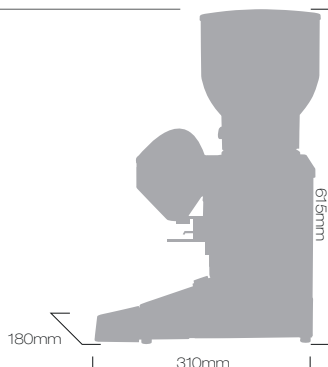

STAINLESS STEEL



MAIN ATTRIBUTES

Hopper (2kg) made of unbreakable and non-deformable material (co.polyester), with fast lock system and self-levelling when off the coffee grinder, with the possibility of cleaning in a dishwasher at 90 °C. Micrometric regulation of the coffee grind using a regulatory pawl. New expulsion system for the ground coffee (always leaving the grinding cavity clean when the coffee grinder stops). Bodywork made of stainless steel, with ventilation system (internal air inlet and outlet). Tray integrated into the bodywork, with ground coffee sweeping system. Made to take knocks (portafilters). Touch screen for easy programming and use (Language selection – Setting the grinding program for each dose – Selection of 1 dose, 2 doses or continuous grinding – Coffee counter: total or partial consumption). Coffee tamper assembled on the body. Hardened steel grinding wheel (62/65 HRc) 60mm in diameter.

Optional: Optional customization system with chromed plate in the front funnel.

